



Using MMX™ Instructions to Implement a Row Filter Algorithm

Information for Developers and ISVs

From Intel® Developer Services
www.intel.com/IDS

March 1996

Information in this document is provided in connection with Intel® products. No license, express or implied, by estoppel or otherwise, to any intellectual property rights is granted by this document. Except as provided in Intel's Terms and Conditions of Sale for such products, Intel assumes no liability whatsoever, and Intel disclaims any express or implied warranty, relating to sale and/or use of Intel products including liability or warranties relating to fitness for a particular purpose, merchantability, or infringement of any patent, copyright or other intellectual property right. Intel products are not intended for use in medical, life saving, or life sustaining applications. Intel may make changes to specifications and product descriptions at any time, without notice.

Note: Please be aware that the software programming article below is posted as a public service and may no longer be supported by Intel.

Copyright © Intel Corporation 2004

* Other names and brands may be claimed as the property of others.

Using MMX™ Instructions to Implement a Row Filter Algorithm

March 1996

CONTENTS

1.0. INTRODUCTION

2.0. THE MMX TECHNOLOGY ROW FILTER ALGORITHM

2.1. Unpacking Pixel Data

2.2. The Filter Loop

2.3. Variations Of Filter Characteristics

2.4. Code Optimization

3.0. LIMITATIONS AND ASSUMPTIONS

3.1. Reentrant Code

3.2. Data Sizes

4.0. MMX TECHNOLOGY PERFORMANCE

5.0. ROW FILTER: C CODE LISTING

6.0. ROW FILTER: MMX CODE LISTING

1.0. INTRODUCTION

The Intel Architecture (IA) media extensions include single-instruction, multi-data (SIMD) instructions. This application note presents examples of code that exploit these instructions. Specifically, the MMxRowFilter function presented here illustrates how to use the new MMX technology unpack, multiply, and add instructions (PUNPCKLW, PUNPCKHW, PMULLW, and PADDW) to apply a filter across the rows of a graphical or video bitmap image. The MMxRowFilter code uses a seven tap filter whose coefficients sum to 256.

The MMX code performance improvement relative to traditional IA code is due to the ability to perform multiplication and addition of 16-bit values in parallel. The equivalent IA instructions IMUL and ADD would take 10 clocks and two clocks respectively. Additionally, the MMX instructions operate on packed 64-bit values which allows four 16-bit words to be multiplied and added in parallel.

2.0. THE MMX TECHNOLOGY ROW FILTER ALGORITHM

The filtering function is defined by the following set of equations:

Example 1. Row Filter Equations

Two-dimension Function: $x(i, j)$ represented by a 32 bit field
 $| (i, j) | r_x(i, j) | g_x(i, j) | b_x(i, j) |$

where each of the elements is 8 bits long

Row Filter Coefficient: $h(j)$

Filter Length: L

Row Filter Output: $y(i, j)$ represented by

$| (i, j) | r_y(i, j) | g_y(i, j) | b_y(i, j) |$

where

$$y(i, j) = \sum_{n=0}^{L-1} x(i, j+n)h(n)$$

$n=0$

$$r_y(i, j) = \sum_{n=0}^{L-1} r_x(i, j+n)h(n)$$

$$g_y(i, j) = \sum_{n=0}^{L-1} g_x(i, j+n)h(n)$$

$$b_y(i, j) = \sum_{n=0}^{L-1} b_x(i, j+n)h(n)$$

The MMX row filter algorithm consists of two sections:

1. The initial section which performs unpacking of data from 32-bit pixels with 8-bit elements for , R , G , and B to 64-bit pixels with 16-bit values for each , R , G , and B element and stores it in a temporary bitmap (array).
2. The filter loop which applies the filter to the bitmap in the temporary array and stores the output to a destination bitmap (array).

The decision to implement MMxRowFilter as two separate loops was made to illustrate the parallelism that can be obtained with the MMX instructions by unrolling different types of loops. An implementation which unpacks two pixels then filters them using one loop was considered. In this case, there was no advantage to doing so, since to calculate the filtered value for $Pixel[n]$, you need to have access to $Pixels[n + L]$, where L is the filter length. This would require unpacking those pixels, so there is no net advantage.

2.1. Unpacking Pixel Data

Data in the source bitmap is stored as 32-bits per pixel with 8-bit elements for , R , G , and B . Since the PMULL instruction operates on packed 16-bit words, we must unpack the data into 64-bit pixels composed of 16-bit elements. Arranging the data in this manner allows us to process in parallel the data for the PMULLW and PADDW instructions in the filter loop. Figure 1 illustrates the fundamental building block of the unpack loop.

Using MMX™ Instructions to Implement a Row Filter Algorithm

March 1996

Figure 1. Unpacking Data

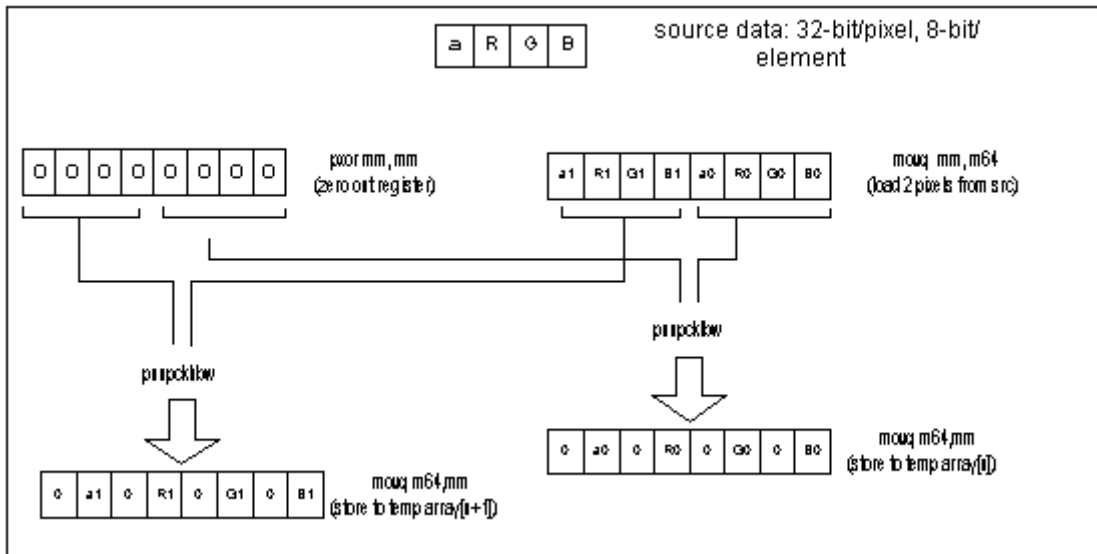

The unpack loop consists of three of the building blocks illustrated in Figure 1. Each building block consumes two registers, (the register containing zeros is preserved). The loop is unrolled such that 6 pixels are unpacked for each iteration of the loop. Data alignment is critical here. Care was taken to align the source buffer on an 8-byte boundary. This is easily done in the C code by allocating buffer on the heap or global space and using compile switches to specify data alignment. One of the alternatives explored was to add three more layers of successive unpacking to yield like pixel components in each register, i.e.:

Unpacking the data in this manner would have allowed us to use the PMADDW instruction in the filter loop thus combining the multiply-accumulate into a single three cycle instruction. This method was discarded due to the number of additional cycles required to further unpack the data to that level.

Example 2. Unpack Code Loop

```

pxor    mm0, mm0                ; Initialize unpack register to zero
unpack:
movq    mm1, [eax]              ; get first two pixels, MSW = PIXn+1 :: LSW =
PIXn

movq    mm3, 8[eax]             ; get next two pixels, MSW = PIXn+3 :: LSW =
PIXn+2

movq    mm2, mm1                ; duplicate first two pixels

punpcklbw mm1, mm0              ; expand PIXn's bytes to 16-bit words
movq    mm4, mm3                ; duplicate next two pixels
movq    mm5, 16[eax]           ; get next two pixels, MSW = PIXn+5 :: LSW =
PIXn+4

punpckhbw mm2, mm0              ; expand PIXn+1's bytes to words
movq    mm4, mm3                ; duplicate first two pixels
punpcklbw mm3, mm0              ; expand PIXn+2's bytes to 16-bit words
movq    0[ecx], mm1             ; PIXn to memory
punpckhbw mm4, mm0              ; expand PIXn+3's bytes to 16-bit words
movq    8[ecx], mm2             ; PIXn+1 to memory
movq    mm6, mm5                ; duplicate next two pixels
movq    16[ecx], mm3            ; PIXn+2 to memory
punpcklbw mm5, mm0              ; expand PIXn+4's bytes to 16-bit words
    
```

Using MMX™ Instructions to Implement a Row Filter Algorithm

March 1996

```
movq      24[ecx], mm4    ; PIXn+3 to memory
punpckhbw mm6, mm0      ; expand PIXn+5's bytes to 16-bit words
movq      32[ecx], mm5    ; PIXn+4 to memory
movq      40[ecx], mm6    ; PIXn+5 to memory
add       ecx, 48         ; increment temp array by 6 pixels
add       eax, 24        ; increment src array pointer by 6 pixels (n+=6)
sub       ebx, 24        ; Decrement loop counter, don't split these two
instr.
jnz       unpack
```

2.2. The Filter Loop

By far, the real work of the algorithm is done in this section. The selection of MMX instructions was predicated by data setup. As mentioned in Section 2.1, the decision to use discrete-multiply-and-accumulate instructions (PMULLW and PADDW) instead of the combined version (PMADDW) is driven by the need to conserve cycles in the unpack loop. The penalty for discrete-multiply-accumulate is one additional clock cycle for the PADDW. However, if care is taken to pair instructions in the Pentium® processor U and V pipes, this additional clock is not seen.

The filter coefficients are represented as 8-bit unsigned fixed-point. Since each pixel element was originally an 8-bit unsigned value, multiplying filter coefficients by pixel elements (R , G , B , and A) yields a 16-bit signed result, with the most significant 8-bits representing the whole part and the least significant eightbits representing the fractional part of the result.

Figure 2. Data Representation for 8-bit Filter Coefficients

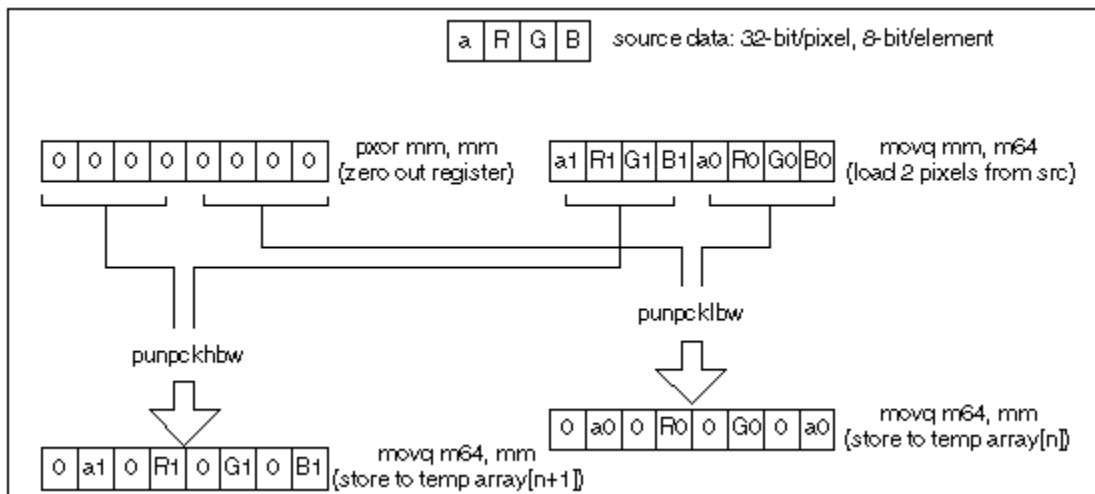

Note that PMULLW is a 16-bit multiply which produces a 32-bit result. Since the pixel color values and filter coefficients were originally 8-bit values, the result of the multiply will contain at most 16 bits. Of this result, only the upper eight bits, or whole part, are significant. This is NOT the case if coefficients are greater than eight bits; this scenario is discussed in the next sections.

The basic building block of the filter loop is the multiply-accumulate (MACC) operation. We cannot use the single PMADDW instruction for MACC since we do not have like elements in the temp array. This same situation also requires that we arrange the filter coefficients in memory accordingly, as illustrated in Figures 3 and 4.

Figure 3. Multiply-Accumulate Operation

Using MMX™ Instructions to Implement a Row Filter Algorithm

March 1996

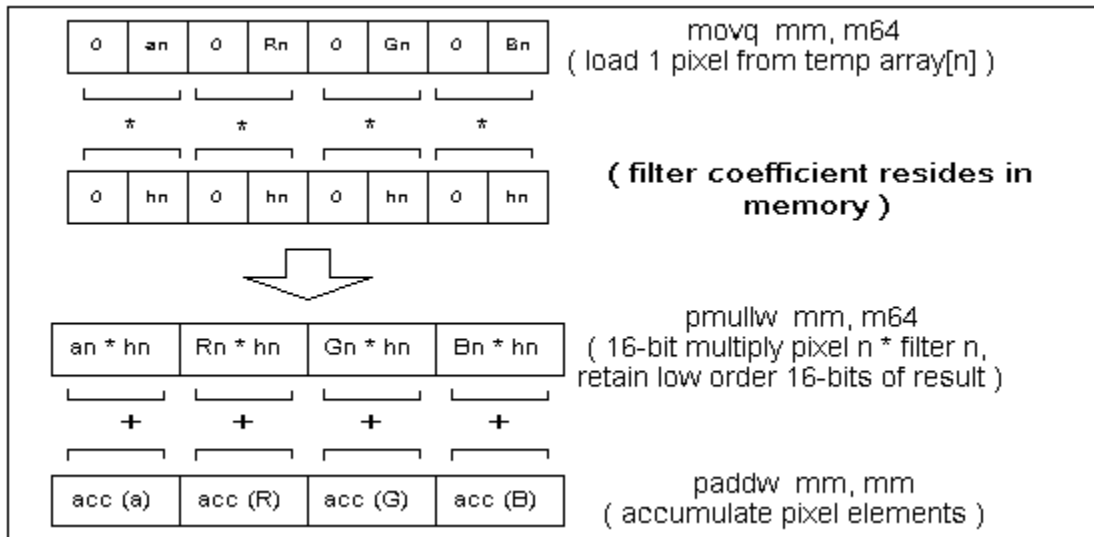
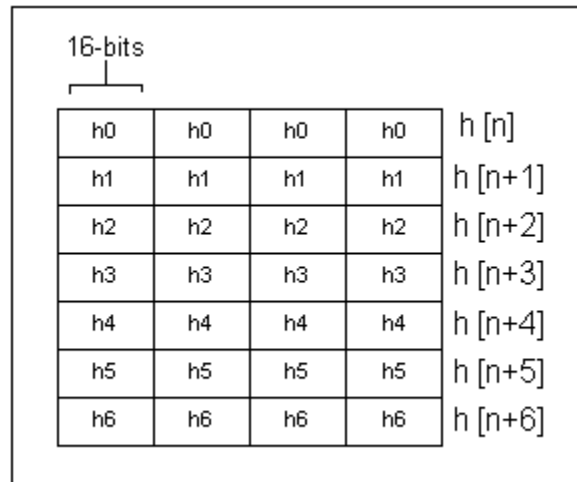

Figure 4. Filter Coefficients for MMX implementation



2.3. Variations Of Filter Characteristics

Coefficient Size

In the code example provided with this application note, we chose a fairly simple set of coefficients to give a straightforward example in instruction pairing and loop unrolling. Typically, however, filter coefficients will NOT be limited to 8-bit fixed-point representation. Let's look at an example where the coefficient require 13 bits of precision. In this case the data representation is shown in Figure 5.

Figure 5. Data Representation for 13-bit Filter Coefficients

Using MMX™ Instructions to Implement a Row Filter Algorithm

March 1996

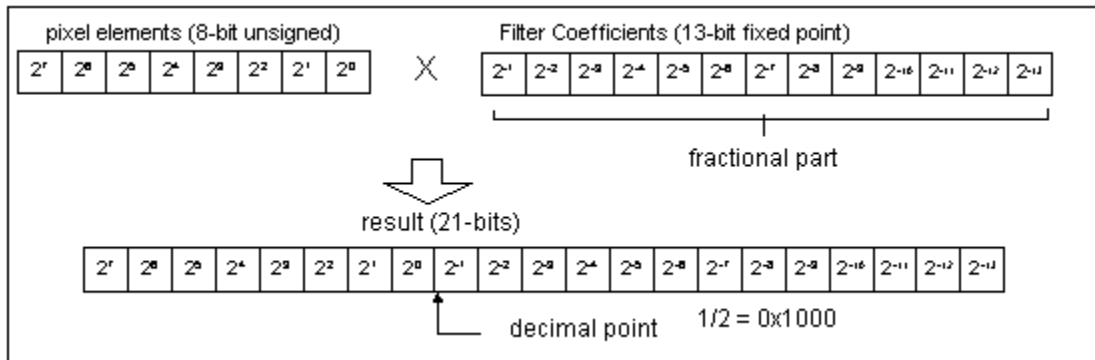

A multiply result greater than 16 bits makes the use of the discrete MACC instructions (PMULLW and PADDW) not efficient since an additional multiply would be required to obtain the high order 16 bits of the result (PMULHW). Additionally, one still needs to combine the 16-bit results for accumulation and this is prohibitively costly in terms of CPU cycles. Some possible alternatives:

- Leave coefficients greater than 8 bits. Restructure the algorithm to unpack like pixel elements into separate arrays. Use the PMADDW instruction to perform the multiply-accumulate, which yields a 32-bit result. Filtered elements then need to be re-packed at the end of the algorithm to place them back into the original pixel format. With this solution, one needs to take steps to alleviate possible overflow conditions. Shifting the coefficient right (one or two LS bits) can take care of this, at the expense of some rounding error. The filter designer must weigh the tradeoffs.
- Scale the coefficients to be ≤ 8 -bits. No changes to the existing algorithm are necessary. The filter designer must again weigh the benefits of doing this vs. the loss in precision.

Filter Length

In the sample code provided with this application note, the number of taps in the filter (filter length) is seven and the code is optimized with this in mind. Realistically this can be any number. To implement a more general case, the developer should consider an inner-loop to implement the filter. The decision of whether to use an inner loop or not depends on the following considerations:

- The availability of regular x86 registers (EAX, EBX, etc....) to use as loop counters and indexes.
- As a general rule, code overhead to manage the loop should not exceed 10% of the loop size.

2.4. Code Optimization

Since the core of the filter operation is relatively straightforward, the trick in implementing an MMX technology version is to take advantage of the parallelism of the instructions, pairing instructions between the U and V pipes and the pipeline multiply instruction. A method useful in identifying optimal pairing scenarios is to use a software pipelining diagram. For purposes of this application note, I'll define software pipelining as: interleaving more than one iteration of an algorithm in order to satisfy the latency and pairing rules as optimally as possible. To use a software pipelining diagram do the following steps:

1. Narrow your instruction selection down to those which consume the least amount of CPU cycles for one functional iteration of an operation and assign a code to it: For example:

```

2.
3.         load:                movq        mm, mem64        =    L
4.         multiply:            pmullw     mm, mem64        =    M
5.         accumulate:         paddw     mm, mm            =    A

```

Using MMX™ Instructions to Implement a Row Filter Algorithm

March 1996

6. Enter the codes in the appropriate pipe positions (U or V) that are dictated by the static pairing rules. e.g., memory accesses can only happen once per clock cycle and must always occur in the U pipe, so enter these first. Note: Using register numbers as subscripts helps highlight possible occurrences of register pressure and helps to plan register usage.
7. Fill in any blank lines (U or V) with remaining instructions.
8. Identify conditions that keep you from further pairing, i.e., too many memory accesses.
9. Identify a solution to alleviate the conditions above and re-enter the table.
10. Iterate as needed.

For this algorithm, all instructions containing memory accesses were entered first, since static pairing rules dictate that memory accesses can only happen once per clock cycle and must always occur in the U pipe. Empty rows were then used to identify pairing opportunities for other instructions.

Table 1 shows the final pipelining diagram for one iteration of the filter loop. In this diagram each column contains the operations performed for each combination of hn and Pn that must be multiplied-accumulated. Additionally, each U and V row pair represents one CPU clock. With this layout, one can easily lay out the algorithm taking into account the static pairing rules.

Table 1. Software Pipelining Diagram

Filter Coefficient	hn	hn	hn+1	hn+1	hn+2	hn+2	hn+3	hn+3	hn+4	hn+4	hn+5	hn+5	hn+6	hn+6
Pixel	Pn	Pn+1	Pn+1	Pn+2	Pn+2	Pn+3	Pn+3	Pn+4	Pn+4	Pn+5	Pn+5	Pn+6	Pn+6	Pn+7
U	L0													
V	I6													
U	M0													
V			D2,1											
U		M1												
V		I7												
U				L3										
V														
U			M2											
V					D4,3									
U				M3										
V	A6,0													
U					M4									
V		A7,1												
U						L0								
V			A6,2											
U							L2							
V							D1,0							
U						M0								
V				A7,3										
U							M1							

Using MMX™ Instructions to Implement a Row Filter Algorithm

March 1996

V					A6,4									
U														
V														
U									D3,2					
V														
U								M2						
V						A7,0								
U										L4				
V							A6,1							
U									M3					
V											D0,4			

Notes:

1. Ld = MOVQ MMD, MEM64 (load a pixel @ mem64 into mm register d, where d= 0-7)
2. Dy,d = MOVQ MMY, MMD (duplicate pixel in mmd into mmy)
3. Md = PMULLW MMD, MEM64 (16-bit multiplication, where mem64 = h, and mmd contains result)
4. Aj,d = PADDW MMJ, MMD (accumulate mmd into mmj)
5. Ij = PXOR MMJ, MMJ (init accumulators to 0)

<i>Table 1. Software Pipelining Diagram (continued)</i>														
Filter Coefficient	hn	hn	hn+1	hn+1	hn+2	hn+2	hn+3	hn+3	hn+4	hn+4	hn+5	hn+5	hn+6	hn+6
Pixel	Pn	Pn+1	Pn+1	Pn+2	Pn+2	Pn+3	Pn+3	Pn+4	Pn+4	Pn+5	Pn+5	Pn+6	Pn+6	Pn+7
U										M4				
V								A7,2						
U												L1		
V														
U										M0				
V													D2,1	
U												M1		
V									A6,3					
U														L3
V										A7,2				
U													M2	
V											A6,0			
U														M3
V												A7,1		
U														
V														
U													A6,2	

Using MMX™ Instructions to Implement a Row Filter Algorithm

March 1996

V															A7,3
U															
V															
U															
V															
U															
V															

Notes:

1. L0 indicates a load of MM0 of Pixel n from memory and therefore must be placed in the U pipe.
2. I6 indicates a pxor of MM6 with itself (clearing accumulator for Pixel n). There can only be one shift operation per clock. But no restrictions on pairing with a memory access since there's no register dependency.
3. M0 indicates a multiply of Pixel n in MM0 with hn in memory. Memory accesses must be placed in U pipe. Note that it is corresponding accumulation A6,0 cannot take place until three clock cycles later in line 14. Since this is not a memory access we place this in the V pipe to conserve U pipe slots for memory operations.
4. D2,1 indicates a duplication of Pixel n+1 in MM1 into MM2. Since there is no memory access or register dependency, it can pair with the memory access in line 3.
5. M1 indicates a multiply of Pixel n+1 in MM0 with hn in memory. Memory accesses must be placed in U pipe. Note that the corresponding L1, is located prior to the loop for the first iteration and near the end of the loop for subsequent iterations.

The loop is unrolled so that optimal pairing can be achieved when performing the MACCs. Examination of Table 1 yields the following general observations:

This implementation of row filter is memory bound. When using MMX instructions you are allowed one memory access per clock and that access is limited to the U pipe.

1. Most clock cycles have a memory access therefore it would be hard to further unroll the loop to expose more parallelism.
2. Duplication of pixels was done to alleviate some of the memory pressure.

When using an MMX multiply instruction, results cannot be accessed until three clocks after the multiply operation. Therefore accumulation of each multiply must happen more than three clocks after the corresponding multiply.

1. Each row where there is a blank line is a place where other instructions may be inserted for pairing purposes.
2. Each loop performs the filter operation on two pixels (P_n and P_{n+1}).
3. Upon completion of the loop MM6 contains the accumulation for P_n and MM7 contains the accumulation for P_{n+1} .

Example 3 shows a code fragment from the filter loop, specifically the first eight clock cycles. This illustrates the interleaving and instruction pairing. Once the cache is full (each line is 32-bytes), memory operations carry no fetch penalty. The performance is the same as using MMX registers as operands.

Example 3. Interleaving of Two MACC Operations

```

pixloop:
    movq    mm0, [eax]        ; load PIXn
    pxor   mm6, mm6          ; zero out the PIXn accumulator
    pmullw mm0, [ebx]        ; PIXn*Hn
    
```

Using MMX™ Instructions to Implement a Row Filter Algorithm

March 1996

```
movq    mm2, mm1        ; duplicate PIXn+1
pmullw  mm1, [ebx]      ; PIXn*Hn
pxor    mm7, mm7        ; zero out the PIXn+1 accumulator
movq    mm3, 16[ebx]    ; load PIXn+2
pmullw  mm2, 8[ebx]     ; PIXn+1*Hn+1
movq    mm4, mm3        ; duplicate PIXn+2
pmullw  mm3, 8[ebx]     ; PIXn+2*Hn+1
paddw   mm6, mm0        ; accumulate Pn
pmullw  mm4, 16[ebx]    ; PIXn+2*Hn+2
paddw   mm7, mm1        ; accumulate Pn+1
```

3.0. LIMITATIONS AND ASSUMPTIONS

3.1. Reentrant Code

The code module supplied is not reentrant, however it can be made reentrant with a few minor modifications:

- Remove the DATA SEGMENT and DATA ENDS directives and the static variables and arrays contained in the data segment.
- Pass pointers to all storage arrays (source, temporary and destination). These should be allocated from the heap outside the MMX code so that the developer can specify the alignment. The developer cannot control the memory alignment of variables declared on the stack. Accesses that are not 8-byte aligned will carry an additional penalty.
- Parameterize the loop counter variables and rounding coefficient.
- If any other variables are needed, make them local to the function.

3.2. Data Sizes

Due to loop unrolling, the current implementation places the following constraints on data sets:

- The source bit-map size must be a multiple of 24-bytes
- The temporary array size must be a multiple of 16-bytes, and must be twice the size of the source array.
- Due to the illustrative purposes of this example, resultant pixels are not calculated for the last 8 (*number of filter taps + 1*) pixels. Some minor reworking of the loop counter and the addition of a loop prolog could be added to remove this constraint.
- Filter length (*number of taps*) = 7.

4.0. MMX TECHNOLOGY PERFORMANCE

Once the cache is filled, the unpack loop executes in an average of 92 clocks per loop. At six pixels per loop, we average 16 clocks/pixel for unpacking.

Once the cache is filled, the filter loop executes in an average of 45 clocks per loop. At two pixels per loop, we average 23 clocks/pixel for the filter.

5.0. ROW FILTER: C CODE LISTING

The C code below is shown to illustrate the functionality of the row filter algorithm. It is not intended to match the implementation of the MMX technology version.

```
void CRowFilter( DWORD p[][IMAGE_WIDTH],
                short *h,
                DWORD q[][IMAGE_WIDTH],
                short nRows,
                short nCols, short hLength )
{
    short    r[IMAGE_HEIGHT][IMAGE_WIDTH];
    short    g[IMAGE_HEIGHT][IMAGE_WIDTH];
    short    b[IMAGE_HEIGHT][IMAGE_WIDTH];
    short    a[IMAGE_HEIGHT][IMAGE_WIDTH];
    DWORD A, R, G, B;
    short i, y, x;
    for (y=0; y<nRows; y++)
    {
        for (x=0; x<nCols; x++)
        {
            b[y][x] = (short) (p[y][x]&0x000000ff);
            g[y][x] = (short) ((p[y][x]>>8)&0x000000ff);
            r[y][x] = (short) ((p[y][x]>>16)&0x0000ff);
            a[y][x] = (short) ((p[y][x]>>24)&0x0000ff);
        }
    }
    for (y = 0; y < nRows; y++)
    {
        for (x = 0; x < nCols-hLength; x++)
        {
            A=0;
            R=0;
            G=0;
            B=0;
            for ( i=0; i<hLength; i++)
            {
                A+= a[y][x+i]*h[i];
                R+= r[y][x+i]*h[i];
                G+= g[y][x+i]*h[i];
                B+= b[y][x+i]*h[i];
            }
            A=A+0x0080;
            R=R+0x0080;
            G=G+0x0080;
            B=B+0x0080;
            q[x] = ((A<<16)&0xff000000) |
                  ((R<<8)&0x00ff0000) |
                  ((B>>8)&0x000000ff);
        }
    }
}
// __asm int 3
} // eo row filter
```

Using MMX™ Instructions to Implement a Row Filter Algorithm

March 1996

6.0. ROW FILTER : MMX CODE LISTING

```
.486P
.Model FLAT, C
IMAGE_WIDTH EQU 72
IMAGE_HEIGHT EQU 58
FILTER_LENGTH EQU 7
_DATA SEGMENT
Arr16 DWORD IMAGE_WIDTH*IMAGE_HEIGHT*2 DUP (0)
rnduparr WORD 4 DUP (128)
srcsize DWORD IMAGE_WIDTH*IMAGE_HEIGHT*4
Arr16siz DWORD (IMAGE_WIDTH*IMAGE_HEIGHT*4*2)-64
pixtemp DWORD 0
_DATA ENDS
_TEXT SEGMENT PUBLIC USE32 'CODE'
MMxRowFilter PROC C PUBLIC USES ebx ecx edi esi, src:PTR DWORD,
; Source bitmap pointer
filt:PTR SWORD, ; Filter pointer
dest:PTR DWORD, ; Destination bitmap pointer
temp:PTR DWORD
mov eax, src ; Source bitmap pointer
mov ebx, filt ; Filter pointer
mov ecx, dest ; Destination bitmap pointer
mov ebx, srcsize
mov ecx, temp
pxor mm0, mm0 ; Initialize unpack register to zero
unpack:
movq mm1,[eax] ; get first two pixels, MSW = PIXn+1 :: LSW = PIXn
movq mm3,8[eax] ; get next two pixels, MSW = PIXn+3 :: LSW = PIXn+2
movq mm2, mm1 ; duplicate first two pixels
punpcklbw mm1, mm0 ; expand PIXn's bytes to 16-bit words
movq mm4, mm3 ; duplicate next two pixels
movq mm5,16[eax] ; get next two pixels, MSW = PIXn+5 :: LSW = PIXn+4
punpckhbw mm2, mm0 ; expand PIXn+1's bytes to words
movq mm4, mm3 ; duplicate first two pixels
punpcklbw mm3, mm0 ; expand PIXn+2's bytes to 16-bit words
movq 0[ecx], mm1 ; PIXn to memory
punpckhbw mm4, mm0 ; expand PIXn+3's bytes to 16-bit words
movq 8[ecx], mm2 ; PIXn+1 to memory
movq mm6, mm5 ; duplicate next two pixels
movq 16[ecx], mm3 ; PIXn+2 to memory
punpcklbw mm5, mm0 ; expand PIXn+4's bytes to 16-bit words
movq 24[ecx], mm4 ; PIXn+3 to memory
punpckhbw mm6, mm0 ; expand PIXn+5's bytes to 16-bit words
movq 32[ecx], mm5 ; PIXn+4 to memory
movq 40[ecx], mm6 ; PIXn+5 to memory
add ecx, 48 ; increment temp array by 6 pixels
add eax, 24 ; increment src array pointer by 6 pixels (n+=6)
sub ebx, 24
jnz unpack
mov eax, temp ; U-pipe: load address of temp array
mov ebx, filt ; load address filter array[0][0]
mov esi, dest
movq mm5, DWORD PTR rnduparr ; load rounding constants (0x0080)
sub esi, 8 ; pre decrement dest array pointer for better
; pairing inside the loop
mov edx, Arr16siz
movq mm1, 8[eax] ; load PIXn+1
pixloop:
movq mm0, [eax] ; load PIXn
pxor mm6, mm6 ; zero out the PIXn accumulator
```

Using MMX™ Instructions to Implement a Row Filter Algorithm

March 1996

```
    pmullw    mm0, [ebx]      ; PIXn*Hn
    movq     mm2, mm1        ; duplicate PIXn+1
    pmullw    mm1, [ebx]      ; PIXn*Hn
    pxor     mm7, mm7        ; zero out the PIXn+1 accumulator
    movq     mm3, 16[eax]     ; load PIXn+2
    pmullw    mm2, 8[ebx]     ; PIXn+1*Hn+1
    movq     mm4, mm3        ; duplicate PIXn+2
    pmullw    mm3, 8[ebx]     ; PIXn+2*Hn+1
    paddw    mm6, mm0        ; accumulate Pn
    pmullw    mm4, 16[ebx]    ; PIXn+2*Hn+2
    paddw    mm7, mm1        ; accumulate Pn+1
    movq     mm0, 24[eax]     ; load PIXn+3
    paddw    mm6, mm2        ; accumulate Pn
    movq     mm2, 32[eax]     ; load PIXn+4
    movq     mm1, mm0        ; duplicate PIXn+3
    pmullw    mm0, 16[ebx]    ; PIXn+3*Hn+2
    paddw    mm7, mm3        ; accumulate Pn+1
    pmullw    mm1, 24[ebx]    ; PIXn+3*Hn+3
    paddw    mm6, mm4        ; accumulate Pn
    movq     mm3, mm2        ; duplicate PIXn+4
    pmullw    mm2, 24[ebx]    ; PIXn+4*Hn+3
    paddw    mm7, mm0        ; accumulate Pn+1
    movq     mm4, 40[eax]     ; load PIXn+5
    paddw    mm6, mm1        ; accumulate Pn
    pmullw    mm3, 32[ebx]    ; PIXn+4*Hn+4
    movq     mm0, mm4        ; duplicate PIXn+5
    pmullw    mm4, 32[ebx]    ; PIXn+5*Hn+4
    paddw    mm7, mm2        ; accumulate Pn+1
    movq     mm1, 48[eax]     ; load PIXn+6
    pmullw    mm0, 40[ebx]    ; PIXn+5*Hn+5
    movq     mm2, mm1        ; duplicate PIXn+6
    pmullw    mm1, 40[ebx]    ; PIXn+6*Hn+5
    paddw    mm6, mm3        ; accumulate Pn
    movq     mm3, 56[eax]     ; load PIXn+7
    paddw    mm7, mm4        ; accumulate Pn+1
    pmullw    mm2, 48[ebx]    ; PIXn+6*Hn+6
    paddw    mm6, mm0        ; accumulate Pn
    pmullw    mm3, 48[ebx]    ; PIXn+7*Hn+6
    paddw    mm7, mm1        ; accumulate Pn+1
                                ; one clock stall due to pmullw latency with mm2
    paddw    mm6, mm2        ; accumulate Pn

                                ; one clock stall due to pmullw latency with mm3
    paddw    mm7, mm3        ; accumulate Pn+1
    paddw    mm6, mm5        ; PIXn : a=a+0x80, r=r+0x80, g=g+0x80, b=b+0x80,
    paddw    mm7, mm5        ; PIXn+1 : a=a+0x80, r=r+0x80, g=g+0x80, b=b+0x80,
    psrlw    mm6, 8          ; shift to obtain whole part of result
    add     esi, 8           ; increment destination pointer by 2 pixels
    psrlw    mm7, 8          ; shift to obtain whole part of result
    add     eax, 16          ; increment temp array pointer by 2 pixels
    packuswb mm6, mm7        ; MSW = PIXn+1 :: LSW = PIXn

    movq     mm1, 8[eax]     ; load PIXn+1 for next iteration of loop
    movq     [esi], mm6      ; store to dest array
    sub     edx, 16
    jnz     pixloop

emms
ret
MMxRowFilter ENDP
_TEXT     ENDS
END
```